

CAUTION!!
 LUMINAIRES MAY BE MULTI
 VOLTAGE CHECK YOUR CIRCUIT
 BOOK OR ENGINEERS DESIGN
 FOR PROPER APPLICATION

USE UG - 3000 SERIES FOR
 LUMINAIRES AND LAMPS IF
 OTHER THAN SHOWN BELOW

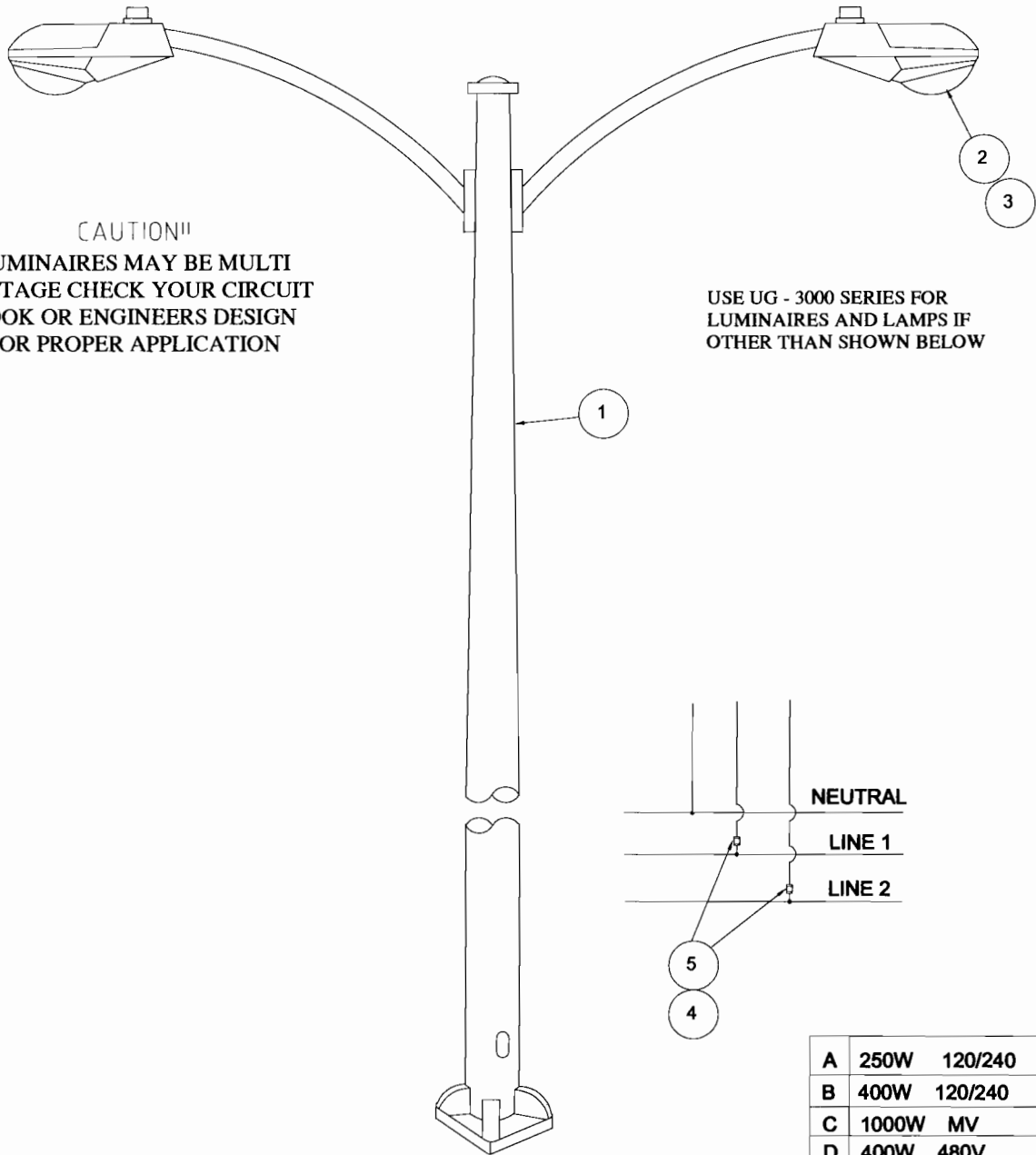

A	250W	120/240
B	400W	120/240
C	1000W	MV
D	400W	480V

TITLE:

MEDIAN STREET LIGHT
 STANDARD

GARLAND

POWER & LIGHT

APPROVED:

STANDARD NO.:

UG - 2920

REVISED:	DATE:	APPROVED:
		CP

CONSTRUCTION STANDARD NO. : UG-2920A**TITLE: MEDIAN STREET LIGHT 250W HPS**

REV. DATE: 5/21/2002

PIC. #	DESCRIPTION	IBM NO.	QTY.
1	POLE ST. LIGHT 30' FIBERGLASS 6' TWIN MAST ARMS	528-67-75300	1
2	LUMINAIRE, 250 WATT, HIGH PRESSURE SODIUM W/ SHORTING CAP, 120VX240V	528-50-17000	2
3	LAMP IGNITRON 250W HPS	528-40-12130	2
4	FUSE, NON-RENEWABLE, 8 AMP. 600 VOLT	285-32-21500	2
5	CONNECTOR FUSED KIT	285-32-60100	2
6	#12 CABLE TYPE SIS STR SWBD 500 FT ROLL- truck stock	280-16-13605	200

CONSTRUCTION STANDARD NO. : UG-2920B**TITLE: MEDIAN STREET LIGHT 400W HPS**

REV. DATE: 6/28/2004

PIC. #	DESCRIPTION	IBM NO.	QTY.
1	POLE ST. LIGHT 30' FIBERGLASS 6' TWIN MAST ARMS	528-67-75300	1
2	LUMINAIRE, 400 WATT HIGH PRESS. SODIUM W/ SHORTING CAP, 120V X 240V	528-50-17005	2
3	LAMP HIGH PRESSURE SODIUM 400W	528-40-12140	2
4	FUSE, NON-RENEWABLE, 8 AMP. 600 VOLT	285-32-21500	2
5	CONNECTOR FUSED KIT	285-32-60100	2
6	#12 CABLE TYPE SIS STR SWBD 500 FT ROLL- truck stock	280-16-13605	200

CONSTRUCTION STANDARD NO. : UG-2920C**TITLE: MEDIAN STREET LIGHT 1000W MERCURY VAPOR**

REV. DATE: 11/1/2005

PIC. #	DESCRIPTION	IBM NO.	QTY.
1	POLE ST. LIGHT 30' FIBERGLASS 6' TWIN MAST ARMS	528-67-75300	1
2	LUMINAIRE 1000 WATT MV W/O PHOTOCELL, 480V	528-50-17830	2
3	LAMP 1000 WATT MV CLEAR 6/CASE	528-40-60240	2
4	FUSE, NON-RENEWABLE, 8 AMP. 600 VOLT	285-32-21500	2
5	CONNECTOR FUSED KIT	285-32-60100	2
6	#12 CABLE TYPE SIS STR SWBD 500 FT ROLL- truck stock	280-16-13605	200

CONSTRUCTION STANDARD NO. : UG-2920D**TITLE: MEDIAN STREET LIGHT 400W HPS 480V**

REV. DATE: 1/28/2010

PIC. #	DESCRIPTION	IBM NO.	QTY.
1	POLE ST. LIGHT 30' FIBERGLASS 6' TWIN MAST ARMS	528-67-75300	1
2	LUMINAIRE, 400 WATT, HPS, 480V W/OUT PHOTO CONTROL RECEPTACLE	528-50-17175	2
3	LAMP HIGH PRESSURE SODIUM 400W	528-40-12140	2
4	FUSE, NON-RENEWABLE, 8 AMP. 600 VOLT	285-32-21500	2
5	CONNECTOR FUSED KIT	285-32-60100	2