

FRONT VIEW

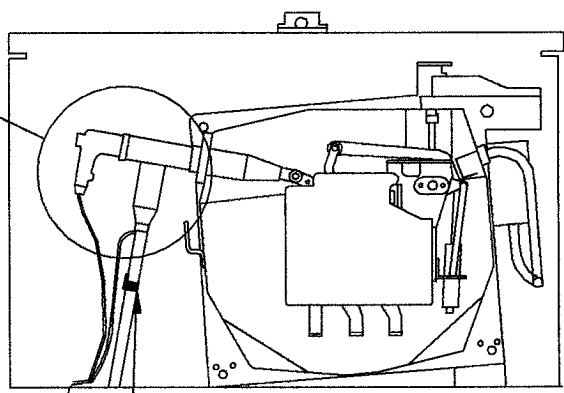

SECTION A-A

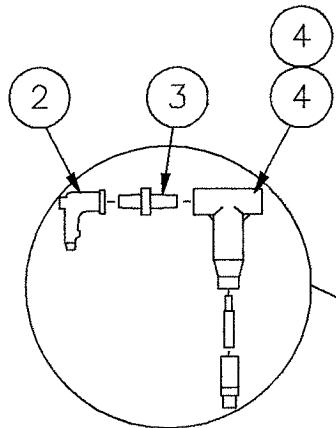

DRAWN BY: GL	DATE: 11/16/04	APPROVED BY: CP
REVISED BY:	DATE:	APPROVED BY:

TITLE:
600-600 AMP SPLIT
BUS AUTO THROWOVER

GARLAND
POWER & LIGHT

STANDARD NO.:
UG-2460

CONSTRUCTION STANDARD NO. : UG-2460**TITLE: 600-600 AMP SPLIT BUSS AUTO THROWOVER - 5 way**

REV. DATE: 3/22/2005

PIC. #	DESCRIPTION	IBM NO.	QTY.
1	SWITCH GEAR 600 AMP DEAD FRONT MAN. OPER. SPRING LOAD, 3-WAY	287-80-84805	1
2	ELBOW T-BODY 600 AMP 1000 MCM 175-220 MIL INSULATION	285-19-19133	12
3	ARRRESTOR, ELBOW, M.O.V. 9KV FOR 200 AMP LOAD BREAK BUSHING	286-04-20010	12
4	PLUG TAP REDUCING FOR 600 AMP ELBOW LOAD BREAK	285-19-19075	12
5	CONNECTOR DOUBLE BOLT SWIVEL CAP CU TO CU 500 MCM	285-18-18520	24
6	FAULT INDICATOR LOAD TRACKER PADMOUNT - SINGLE PHASE	286-30-10345	12
7	CLAMP GROUND ROD 5/8"	285-13-16025	1
8	ROD GROUNDING 5/8" X 8'	285-36-15108	1