

SECTION A-A

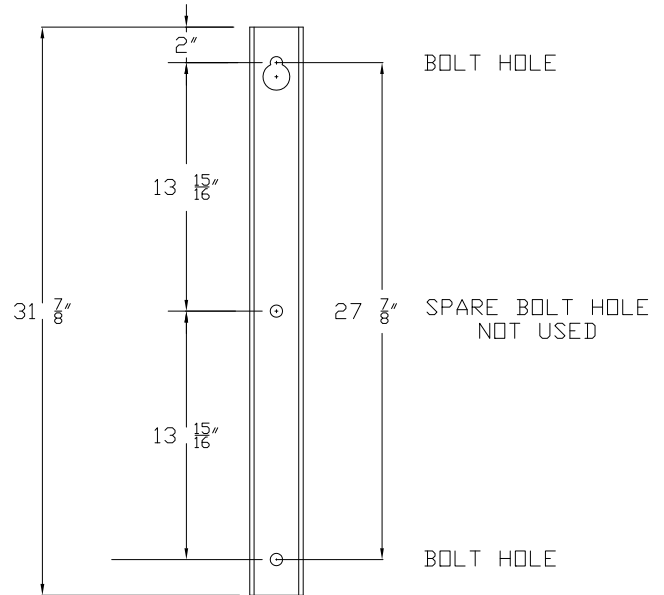

A	250W HPS EQUIVALENT
B	400W HPS EQUIVALENT

TITLE:

LED 250W OR 400W  
HPS EQUIVALENT LIGHT  
ON 13.5' MAST ARM  
(FOR STEEL POLES)

**GARLAND**  
POWER & LIGHT

STANDARD NO.:

OH-1016

DRAWN BY: CY/JC	DATE: 1/25/16	APPROVED BY: DM 2/1/16
REVISD BY:	DATE:	APPROVED BY:

**Construction Standard No.**

**OH-1016A**

Title: LED 250 WATT HPS EQUIVALENT LIGHT ON 13.5' MAST ARM  
(FOR STEEL POLES)

Rev. Date: 1/7/2016

Pic #	Description	IBM NO.	Qty
1	ARM MAST 13.5' FOR STEEL POLES	528-67-42320	1
2	LUMINAIRE, GRAY LED, 250 WATT HPS EQUIVALENT	528-50-17030	1
3	NODE PHOTOCONTROLLER ROAM REN127NN1J50 50/BX	528-65-13000	1
4	ALL THREAD ROD 5/8" (TOOL ROOM)	NOT IN INV	1
5	WASHER SPRING DOUBLE COIL 5/8" 500/BX	285-08-85430	4
6	NUT 5/8" SQ MACHINE	285-08-56634	4
7	#12 CABLE TYPE SIS STR SWBD 500 FT ROLL- truck stock	280-16-13605	20'

**Garland Power & Light**



**OH-1016A**

# Construction Standard No.

# OH-1016B

Title: LED 400 WATT HPS EQUIVALENT LIGHT ON 13.5' MAST ARM  
(FOR STEEL POLES)

Rev. Date: 1/7/2016

Pic #	Description	IBM NO.	Qty
1	ARM MAST 13.5' FOR STEEL POLES	528-67-42320	1
2	LUMINAIRE, GRAY LED, 400 WATT HPS EQUIVALENT	528-50-17040	1
3	NODE PHOTOCONTROLLER ROAM REN127NN1J50 50/BX	528-65-13000	1
4	ALL THREAD ROD 5/8" (TOOL ROOM)	NOT IN INV	1
5	WASHER SPRING DOUBLE COIL 5/8" 500/BX	285-08-85430	4
6	NUT 5/8" SQ MACHINE	285-08-56634	4
7	#12 CABLE TYPE SIS STR SWBD 500 FT ROLL- truck stock	280-16-13605	20'

Garland Power & Light



OH-1016B