

SECTION A-A

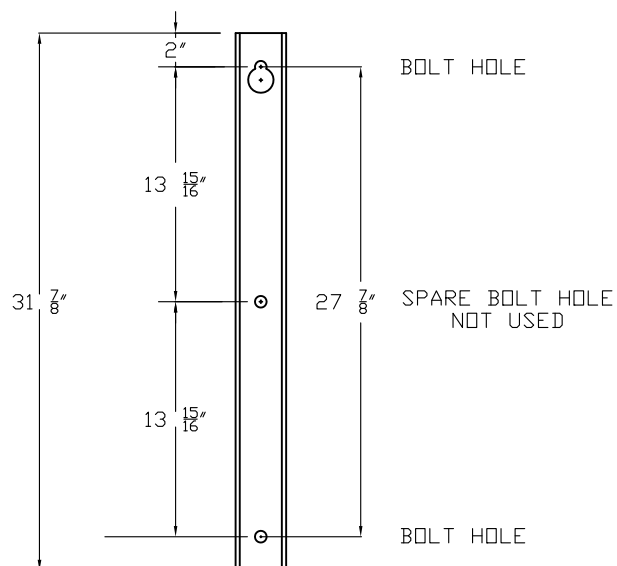

A	250W HPS
B	400W HPS

DRAWN BY: JC	DATE: 9/20/11	APPROVED BY:
REVISED BY:	DATE:	APPROVED BY:

TITLE:
250W OR 400W HPS
LIGHT ON 13.5' MAST
ARM TYPICAL
INSTALLATION FOR
STEEL POLE

GARLAND
POWER & LIGHT

STANDARD NO.:
OH-1006

